



ASSEMBLY INSTRUCTION

**ASTORIA RECLINER**

ITEM CODE: 74843

Imported by Amart Furniture Pty Ltd, Qld, Brisbane Australia.

For any assistance with assembly or for missing parts please phone  
Amart Furniture, Customer Service Free call 1800 351 084

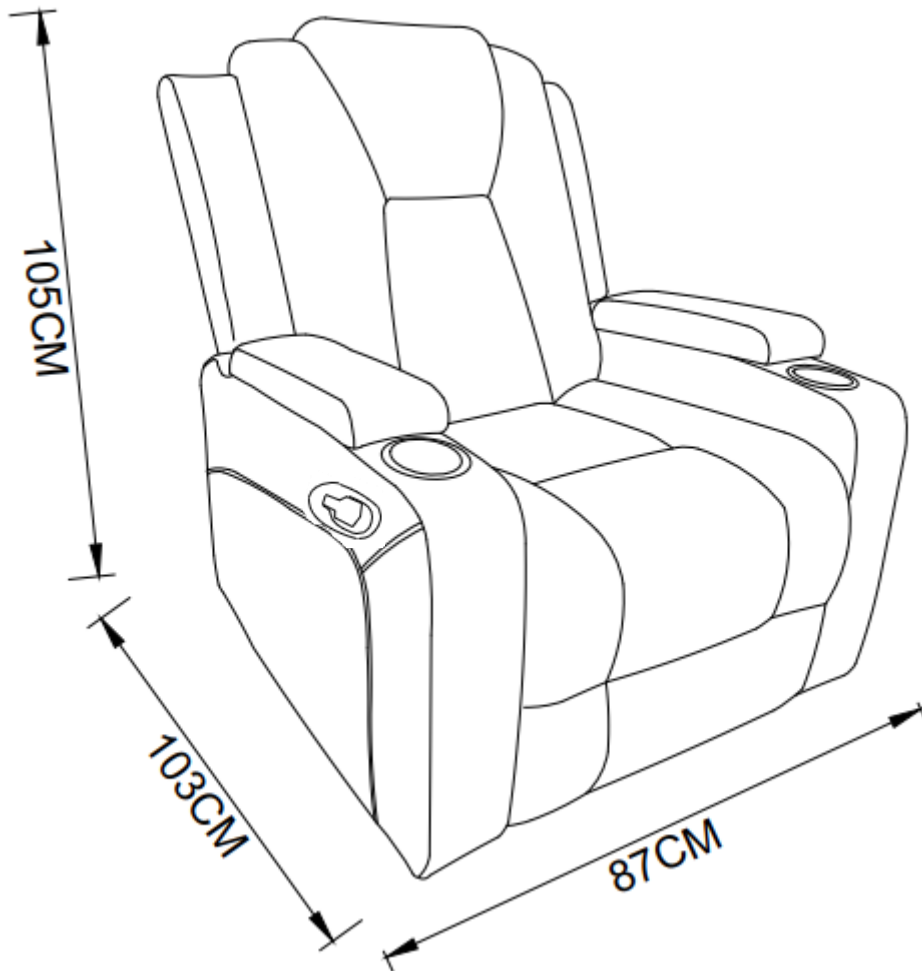

Imported by Amart Furniture Pty Ltd, Qld, Brisbane Australia.

For any assistance with assembly or for missing parts please phone  
Amart Furniture, Customer Service Free call 1800 351 084

## PRE-ASSEMBLY PREPARATION

Before you start:

1. Choose a clean, level, spacious assembly area. Avoid hard surfaces that may damage the product
2. Take care when lifting. Product should be assembled as near as possible to the point of use
3. Ensure that you have all required contents for complete assembly
4. Always read the assembly instructions carefully before beginning assembly.
5. Keep all hardware parts and packaging out of reach of small children.
6. Do not over tighten the screws and bolts as this may damage the threads



ALLOW **5** MINUTES







**1** PEOPLE REQUIRED

### **WARNING**

Do Not allow children to play on this mechanised furniture or operate the mechanism. Leg rest folds down on closing so that a child could possibly be injured. Always leave in an upright and closed position. Keep hands and feet clear of mechanism. Only the occupant should operate it.

# Parts List

①		Side Back (R)	1 PC
②		Side Back (L)	1 PC
③		Back	1 PC
④		Seat	1 PC
⑤		LED Transformer	1 PC

Caution; Do not allow children to play on motion furniture or operate the mechanisms, Serious injury or death may result. Leg rest folds down upon closing potentially causing crushing, pinching or severing of limbs, The furniture may be unstable in its extended position. If unattended always leave in an upright and closed position. Only adults should operate this mechanism. Always keep hands and feet clear of the mechanism. **CEIRO**

# HOW TO ASSEMBLE YOUR NEW KD BACK SYSTEM

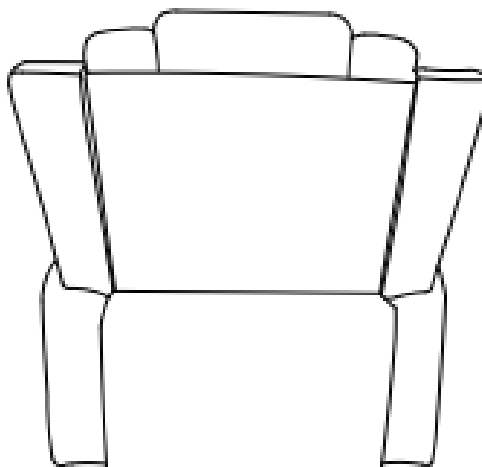
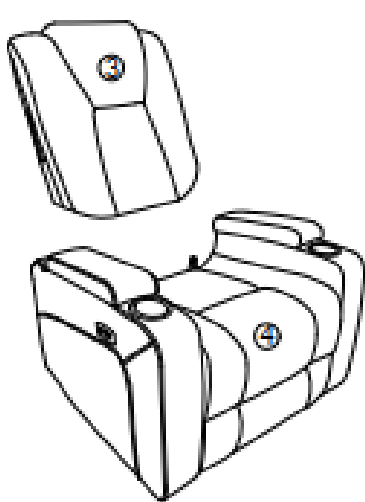

## **Step 1:**

To assemble back, attach ③ to ④ by placing bracket A into sleeve B and press down firmly to lock retaining clip into place. Listen for the clip to pop into place securely.

**Step 2:** Insert the connection point on ① , ② into the catch on side of ③ and slide into place.

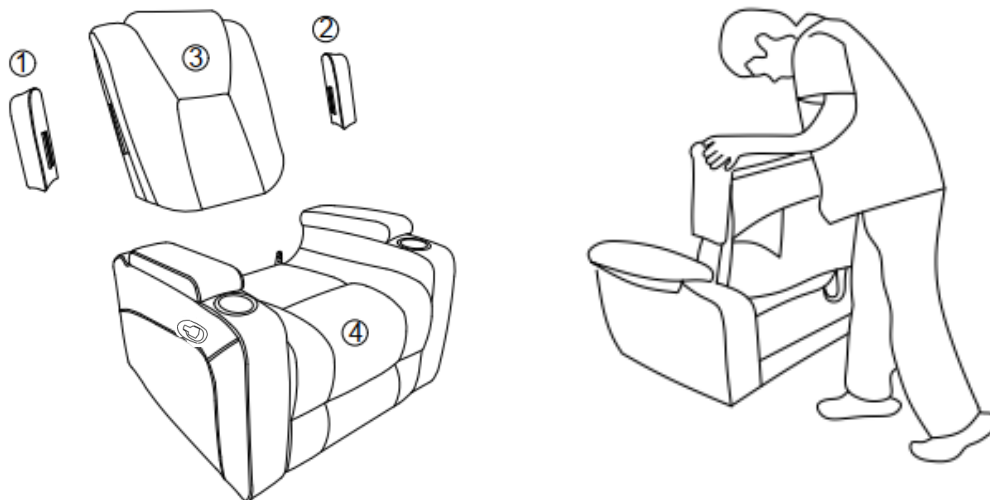

**Step 3:** Connect the power adapter as pictured below .

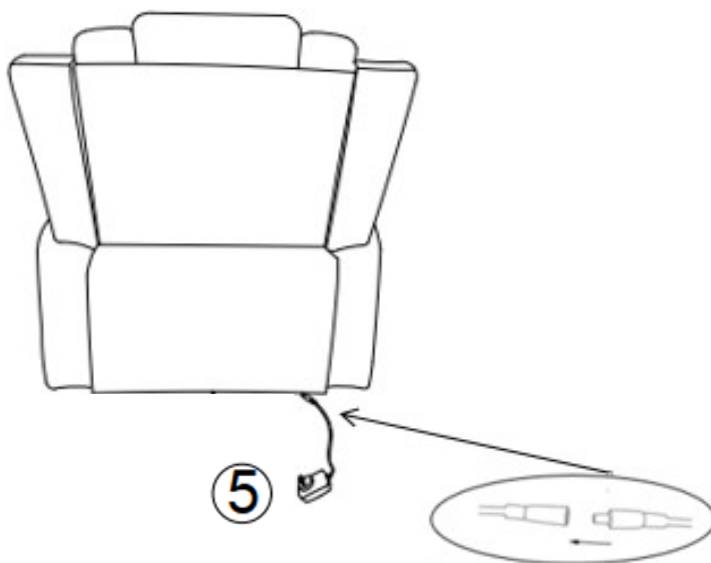

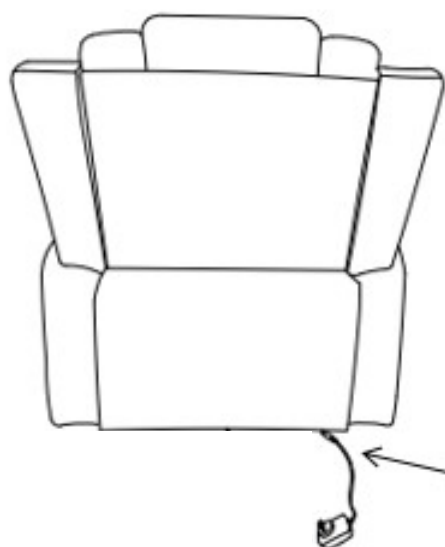

**Safety Note: Transformer and cables are not to be placed under or within the recliner structure.**



## **READ THESE INSTRUCTIONS THOROUGHLY BEFORE USE:**

**DANGER:** TO REDUCE THE RISK OF ELECTRIC SHOCK:  
Always unplug from electric outlet before cleaning.

**WARNING:** RISK OF INJURY  
Keep children away from extended footrest and any moving parts.

**CAUTION:** Do not allow children to play on this electric recliner or operate the powered mechanism. The leg rest folds when closing and could possibly cause injury to a child. Always leave the recliner in an upright and closed position when not in use. Keep hands and feet clear of mechanism. Only the occupant should operate it.

### **POWER CORD SAFETY**

**WARNING:** Unplug and remove power cord from wall when not in use and store out of reach of children.

Take care when moving recliner that wall and transformer cords are not under the base or they may get damaged.

- NEVER OPERATE ELECTRIC RECLINER IF IT HAS A DAMAGED CORD OR PLUG.

**WARNING:** TO REDUCE RISK OF BURNS, FIRE, ELECTRIC SHOCK OR PERSONAL INJURY TO PERSONS:

- Use only for its intended purpose
- Never press or activate control switch if you are not seated in recliner
- Only the occupant should activate the control switch
- Never operate with more than one person occupying seat
- Never sit or stand on the footrest

# Assembly is complete

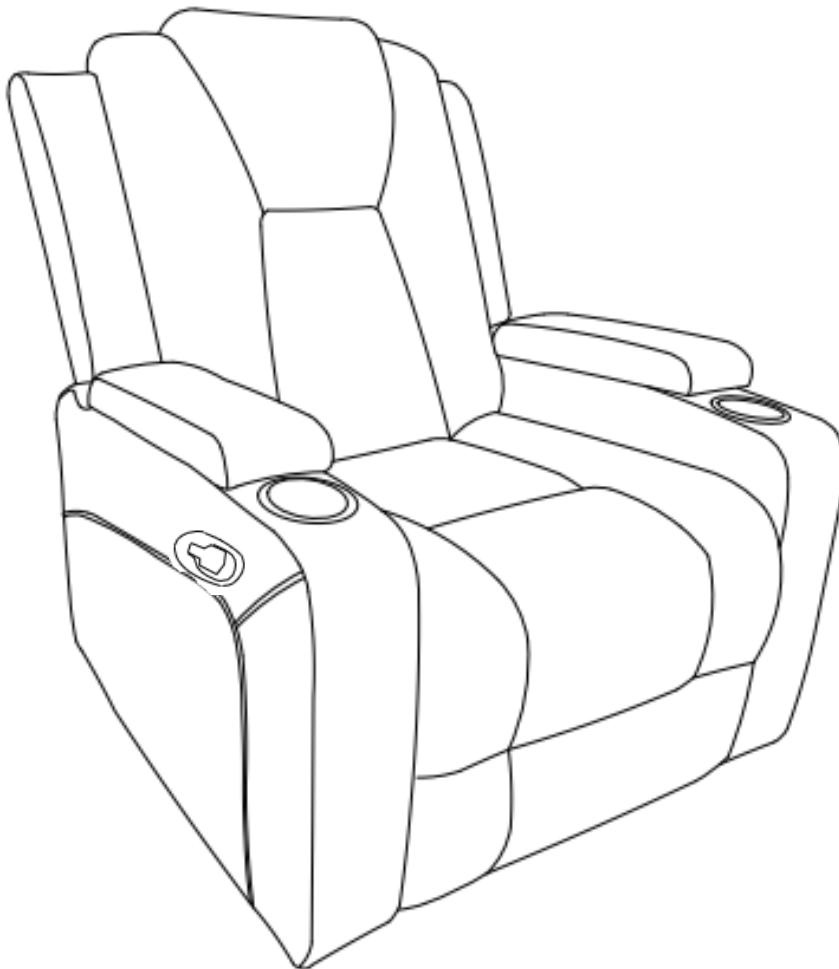

The LED strip lights is a smart strip light that can be controlled by a push button

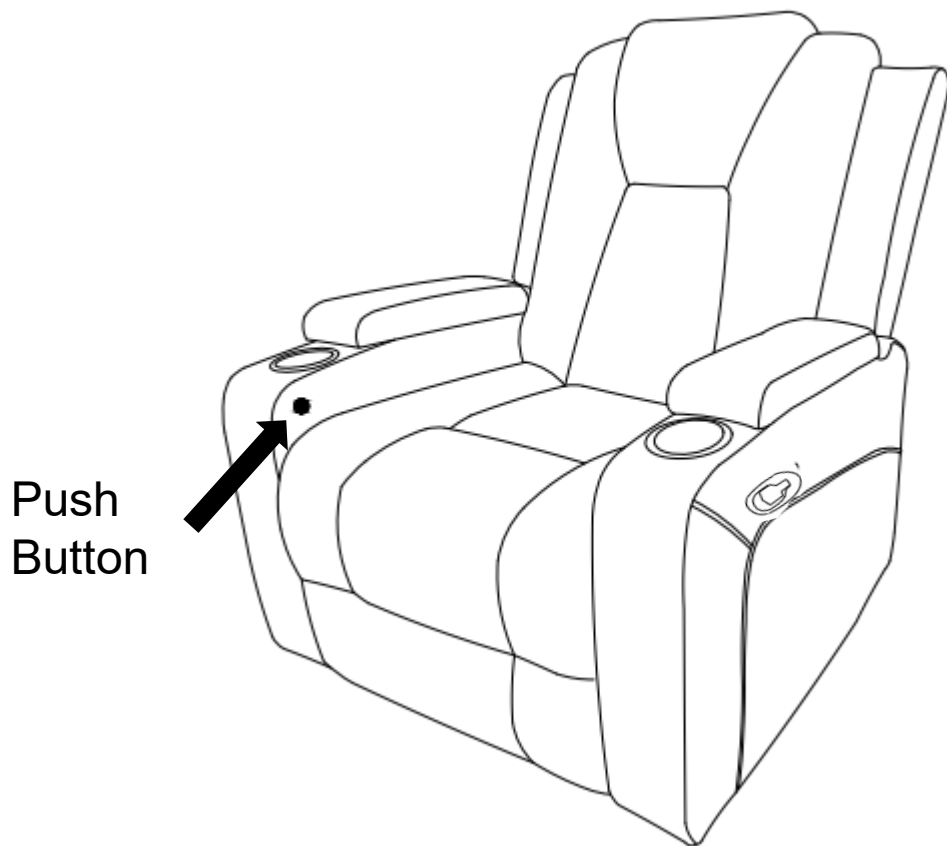



## BACK ASSEMBLY INSTRUCTIONS RECLINER/MOTION UPHOLSTERY

**CAUTION:** PLEASE READ ALL INSTRUCTIONS CAREFULLY BEFORE STARTING THE ASSEMBLY PROCESS

IT IS RECOMMENDED TO USE TWO PEOPLE WHEN ASSEMBLING AND REMOVING THE INSIDE BACKS TO AND FROM THE BASE OF THE FURNITURE.

**STEP 1:** Slide inside back receivers into the steel mechanism posts in the base of the furniture (Figure A).

**STEP 2:** Press both sides of the inside back firmly into place. The inside back automatically locks in place.

**STEP 3:** To remove the inside backs, use a screwdriver pressing outward on the black tab in the metal sleeve (Figure B) on both sides of the inside back and lift the inside back from the base of the furniture.

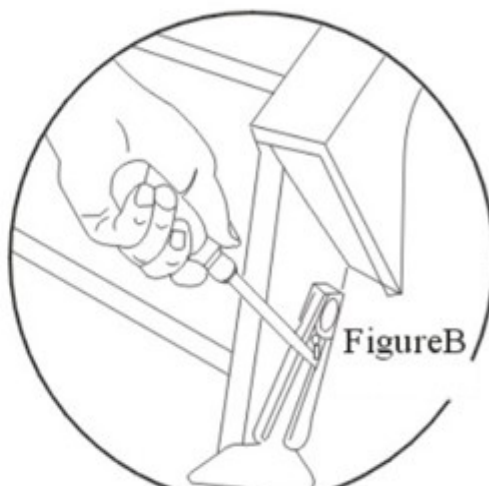
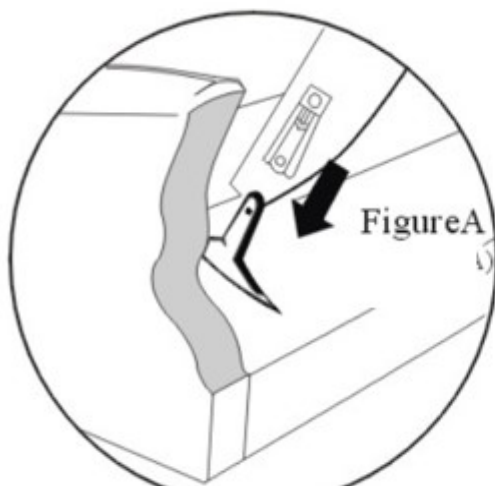

## **REGULAR CARE:**

- \* Protect from direct sunlight
- \* Vacuum regularly using low suction
- \* Rotate reversible cushions regularly

## **CLEANING:**

- \* Do not remove cushion covers for separate cleaning even though they may have zippers
- \* Do not wash . Do not dry clean. Do not shampoo clean
- \* Clean with hot water extraction machine. Professional cleaning recommended
- \* Do not use dishwashing liquid or laundry detergent
- \* Use only upholstery detergents
- \* Do not wet filling
- \* Dry in shade away from direct heat and sunlight
- \* Allow to dry thoroughly before re-use

## **SPOT CLEANING**

- \* Do not rub
- \* Do not spot clean with any solvent
- \* Treat spills and stains as soon as possible
- \* Gently scrape off any soil or mop and liquid from the surface of the fabric
- \* Apply proprietary cleaning agents strictly according to instructions to remove the residue or the spill
- \* Do not saturate the fabric or interior with water or other cleaning liquids

## **WARNING:**

Apply only water-based soil resist (fabric protection) treatments. Do not use aerosol products

- \* **PILLING IS NOT A FABRIC DEFECT OR FAULT AND IS NOT COVERED BY WARRANTY**
- \* **PILLING IS A NORMAL OCCURRENCE IN WOVEN FABRICS AND DOES NOT AFFECT THE DURABILITY OR FUNCTIONALITY OF THE FABRIC. IT IS EASILY REMOVED BY USE OF A BATTERY OPERATED DE-PILLING MACHINE AS THE NEED ARISES**